



Culligan®



REVERSE OSMOSIS

IW EVO

INDUSTRIAL WATER. EVOLVED.



IW EVO

INDUSTRIAL WATER. EVOLVED.

INDUSTRIAL WATER. EVOLVED.

The Culligan **IW Evo Brackish Reverse Osmosis** series has been designed to meet the needs of the most demanding industrial and municipal applications.

Available in **7 models** covering flow requirements of **5 to 40m³/hr** (22 to 176 GPM) and capable of treating salinities up to 3000ppm of TDS.

Using an innovative modular and standardised design Culligan is able to offer the **highest quality construction, fast delivery times and competitive pricing.**

Using the latest reverse osmosis membrane technology over **99% of contaminants** such as dissolved minerals, bacteria, particles, and other impurities **are removed**; producing high purity water suitable for exacting usages such as boiler feed water.

All units are assembled and tested in the Culligan factory in Italy and are skid mounted for simple installation and easy start-up.

STANDARD FEATURES

- Mounted on a frame made from galvanised steel with anti-corrosion paint coating
- Multi-stage high pressure pump with high grade AISI 316 Stainless steel, dry running protection and low noise / high efficiency IE3 motor.
- Ultra-low pressure, high rejection 8" membranes
- 5 micron pre-filtration with stainless steel housing
- All high pressure pipework in 316 Stainless steel
- Low pressure pipework in PN16 U-PVC
- Local pressure measurement
- Local flow measurement on product, reject and recirculation

TOTAL FLEXIBILITY - A complete range of pre-engineered options can be selected and added to the entry level IW Evo unit allowing users to quickly specify the unit that perfectly meets their specific needs.

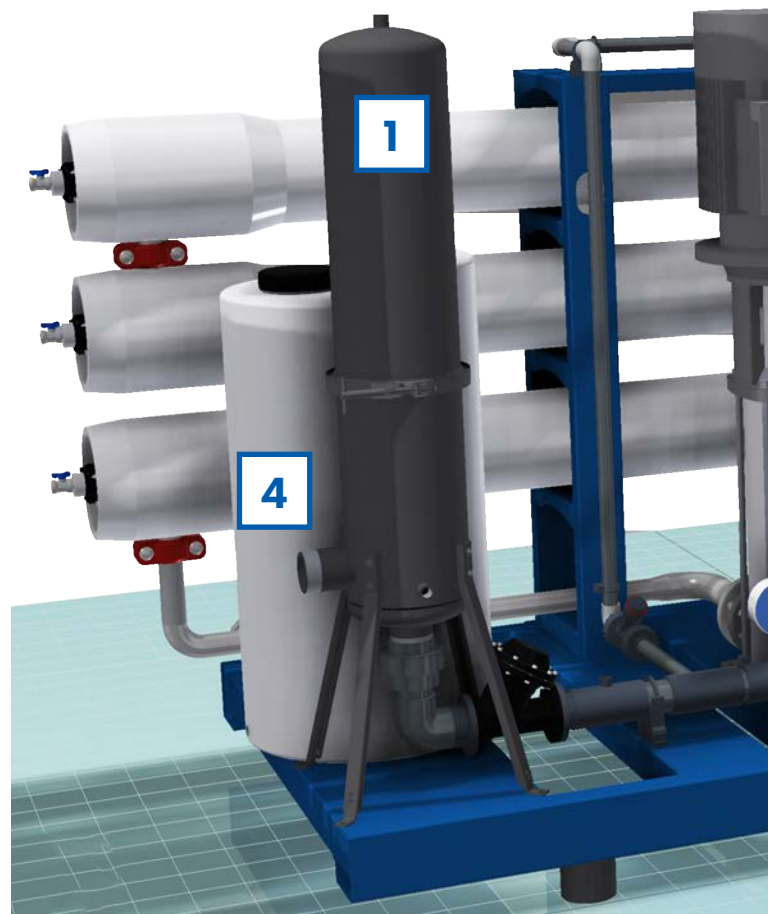

BENEFITS INCLUDE:

- Skid-mounted with no assembly; plug-and-play simplicity
- Flexible, with configure to order options
- Exclusive Culligan Electronics
- Worldwide technical & service support
- Made in Italy
- Fully CE compliant

OPTIONS & UPGRADES FOR TOTAL FLEXIBILITY

1 Additional pre-filtration 20 micron cartridge-filtration unit*. Ideal when dealing with poor quality influents.

2 Monitor every aspect of the units operation with advanced Instrumentation options

- Conductivity**
- Inlet REDOX
- Product pH

3 Extend the life of the membranes using the Integrated flushing tank option. Each time the unit shuts down or during alarm conditions the unit will flush the membranes with treated product water.

4 Integrated Antiscalant dosing station – prevent membrane scaling with Culligan Scale-Guard Antiscalant dosed from the dosing station with auto-start/stop, and tank level functionality.

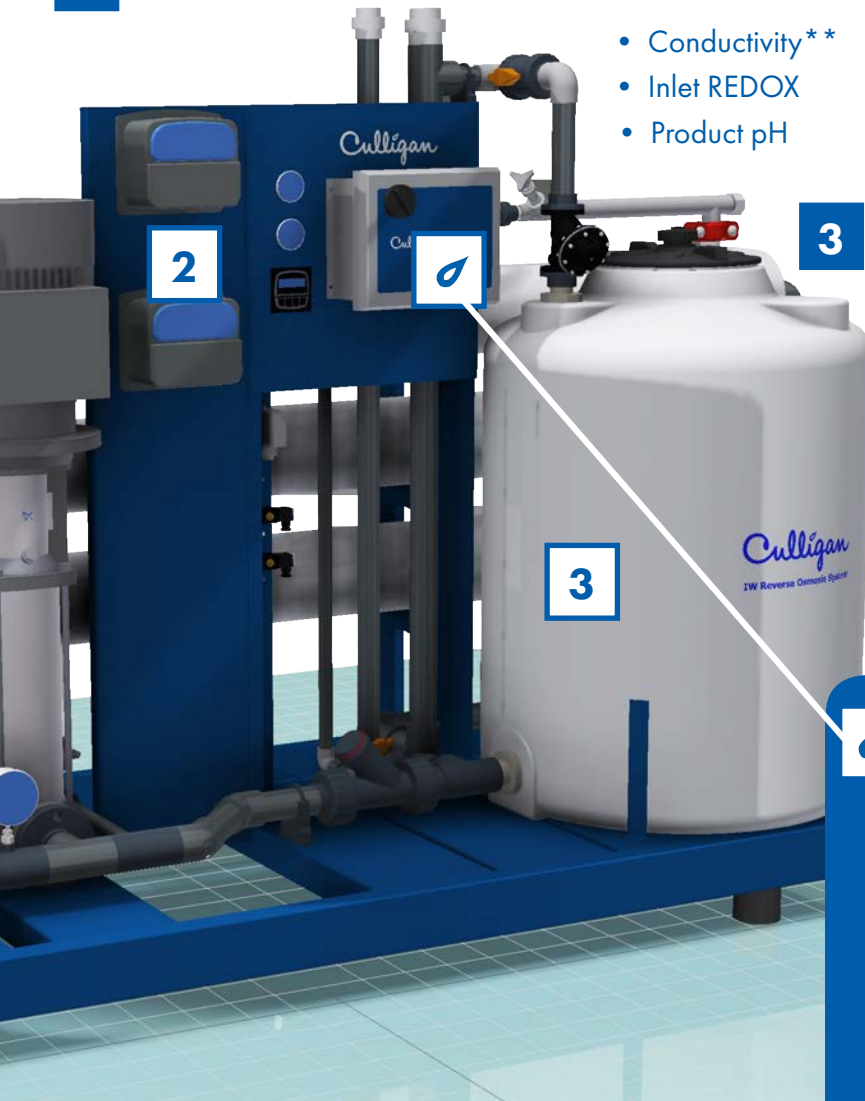

Culligan Smart Controller

The Culligan Smart Controller automates operation, with Digital Flow Meters, Pressure Transducers and Conductivity measurements, as well as a host of other advanced functionality more commonly found in PLC controls, including:

- Monitoring of all system parameters – flow, pressure, quality
- Lighted full text display – available in 4 languages
- Membrane recovery & reject monitoring
- Programmable Alarms & actions on multiple parameters
- User selectable Flush Options & automatic control
- Connectivity options including Modbus, RS232, RS485, USB, & Profibus
- Remote display option available
- Historical data storage.

POWER & CONTROL OPTIONS

- **Quick connection kit - Pre-wired junction box** for easy integration into existing control systems.
- **PLC connection pack** for connection into a central PLC system. Includes 4-20mA pressure and flow instrumentation.

*Due to space limitations options Additional filter cartridge unit & Antiscalant station only available together on models IW16-40

**Inlet and product conductivity are included within the Smart Controller option kit.

MODEL	IW Evo 5	IW Evo 8	IW Evo 12	IW Evo 16	IW Evo 24	IW Evo 32	IW Evo 40	
Nominal Flow ⁽¹⁾ m ³ /h (GPM)	5 (22)	8 (35)	12 (53)	16 (70)	23 (101)	32 (141)	36 (158)	
Membrane Quantity	4	6	9	12	18	24	30	
Vessels x membranes per stage	1° 2° 3°	1X4 1X3	1X3 1X3 1X3	2X6	2X6 1X6	3X6 1X6	3X6 2X6	
Pump power (kW) 380V ~ 50Hz-3pH	4	7,5	11	15	15	22	22	
Piping : Low Pressure	PVC	PVC	PVC	PVC	PVC	PVC	PVC	
Piping : High Pressure	AISI316	AISI316	AISI316	AISI316	AISI316	AISI316	AISI316	
Connections								
Feed	1.5"	2"	2"	3"	3"	4"	4"	
Product	1,5"	1,5"	2"	2"	2.5"	3"	3"	
Reject	1"	1"	1,5"	1.5"	2"	2"	2"	
Dimensions mm (inches)	A B C	4678x (184.1x) 1195x 47x 1900 (74.8)	3720x (146.5x) 1195x 47x 1940 (76.3)	3720x (146.5x) 1195x 47x 1940 (76.3)	6750x (265.7x) 1250x (49.2x) 1985 (78.1)	6750x (265.7x) 1250x (49.2x) 2130 (83.8)	6750x (265.7x) 1250x (49.2x) 2130 (83.8)	6750x (265.7x) 1250x (49.2x) 2130 (83.8)
Weight KG (lb)		650 (1433)	710 (1565)	950 (2095)	1280 (2821)	1370 (3020)	1600 (3527)	1850 (4080)

¹Under standard design limits - Nominal capacity based on new RO membranes operating at 75% recovery on a properly pre-treated feed water of 1500 ppm TDS as NaCl, 20 oC, Silt Density index (SDi) below 3, and supplying water to atmosphere

MATERIALS OF CONSTRUCTION

Frame	Epoxy painted galvanised Steel
Membrane Elements	Hydranautics ESPA Max ultra low pressure, high rejection 8" membranes
Membrane Housing	FRP
Low Pressure Pipe	U-PVC PN16
High Pressure Pipe	Stainless Steel 316
Cartridge filter housing	Stainless Steel 316

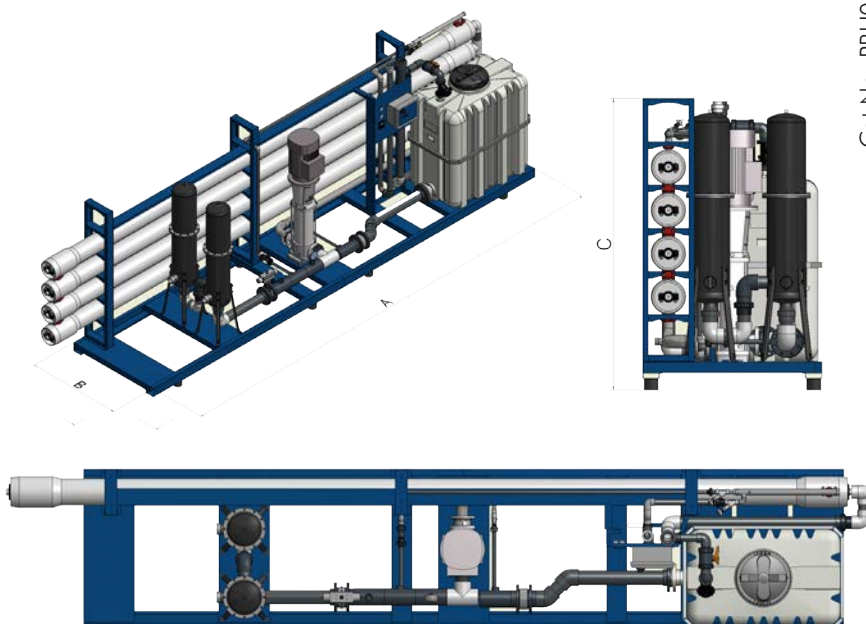

Contact your local Culligan representative for more details

Culligan reserves the right to change any technical or design specifications for the models shown in this brochure.

Place your commercial and industrial water treatment needs in the hands of a global leader.

For over 80 years, Culligan has made better water. Our global network, comprised of 900+ dealers and international licensees in over 90 countries, is dedicated to addressing your water-related problems. As a worldwide leader in water treatment, our sales representatives and service technicians are familiar with the local water conditions in your area. Being global and local position us to deliver customized solutions to commercial and industrial water issues that affect your business and your bottom line.